

7-11-2008

A Phylogenetic Analysis of North American Lasius Ants Based on Mitochondrial and Nuclear DNA

Trevor Manendo
University of Vermont

Follow this and additional works at: <http://scholarworks.uvm.edu/graddis>

Recommended Citation

Manendo, Trevor, "A Phylogenetic Analysis of North American Lasius Ants Based on Mitochondrial and Nuclear DNA" (2008).
Graduate College Dissertations and Theses. Paper 146.

This Thesis is brought to you for free and open access by the Dissertations and Theses at ScholarWorks @ UVM. It has been accepted for inclusion in Graduate College Dissertations and Theses by an authorized administrator of ScholarWorks @ UVM. For more information, please contact donna.omalley@uvm.edu.

**A phylogenetic analysis of North American *Lasius* ants based on mitochondrial
and nuclear DNA.**

A Thesis Presented

by

Trevor Manendo

to

The Faculty of the Graduate College

of

The University of Vermont

**In Partial Fulfillment of the Requirements
for the Degree of Master of Science
Specializing in Biology**

May, 2008

Accepted by the Faculty of the Graduate College, The University of Vermont in Partial fulfillment of the requirements for the degree of Master of Science specializing in Biology.

Thesis Examination Committee:

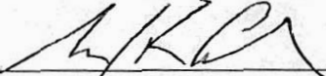

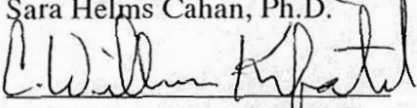
Sara Helms Cahan, Ph.D. **Advisor**

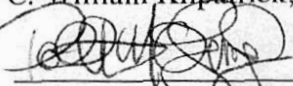
C. William Kilpatrick, Ph.D.

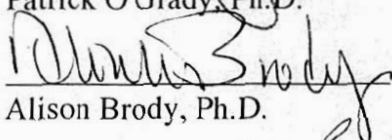
Patrick O'Grady, Ph.D.

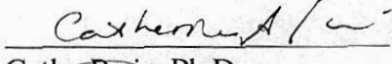
Alison Brody, Ph.D.

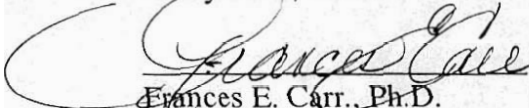
Cathy Paris, Ph.D. **Chairperson**

Frances E. Carr., Ph.D. **Vice President for Research
and Dean of Graduate Studies**

Date: **March 19, 2008**

ABSTRACT

The ant genus *Lasius* (Formicinae) arose during the early Tertiary approximately 65 million years ago. *Lasius* is one of the most abundant and widely distributed ant genera in the Holarctic region, with 95 described species placed in six subgenera: *Acanthomyops*, *Austrolasius*, *Cautolasius*, *Chthonolasius*, *Dendrolasius* and *Lasius*. Many species of *Lasius* have been central to numerous species-level studies and the focus of many ecological, agricultural, and behavioral investigations. The focus of this study was to use molecular phylogenetic analysis of 781 base pairs of the mitochondrial gene cytochrome oxidase I (COI) and 251 base pairs of an anonymous nuclear gene (ANG) to address questions about the evolutionary relationships of North American *Lasius* species and subgenera. These relationships were used to better understand the biological and evolutionary complexities associated with these species given their North American distributions. The resulting hypotheses generated in this study from the analyses of these genes produced unexpected patterns of phylogenetic placement of *Lasius* species and subgenera. A number of biological processes alone or together could explain these patterns, including interspecific hybridization and gene introgression, incomplete lineage sorting, and the presence of multiple cryptic species.

TABLE OF CONTENTS

	Page
Acknowledgments.....	ii
List of Tables.....	iv
List of Figures.....	v
Chapter 1	
1.1 Introduction.....	1
1.2 Methods.....	9
1.3 Results.....	12
1.4 Discussion.....	17
Literature Cited.....	30
Tables.....	34
Figures.....	43

ACKNOWLEDGMENTS

I am very thankful to all of the people who have helped me in my research and academic experiences that have led to the completion of my Master's degree. I especially acknowledge my advisors Dr. Sara Helms Cahan and Dr. Patrick O'Grady for their support and resources that have made this research possible. I also acknowledge each of my research committee members Dr. C. William Kilpatrick, Dr. Alison Brody, and Dr. Catherine Paris for all of their support and advice, as well as Dr. Ken Helms for his advice. I would like to thank many of my fellow graduate students for their support and advice with special thanks given to Ryan Norris. I acknowledge Dr. Phil Ward at the University of California at Davis, Dr. Alex Wild, Dr. Andrew Suarez at the University of Illinois at Urbana-Champaign, and Dr. Jack Longino at Evergreen State College, Olympia Washington for the samples they have supplied. I thank Stefan Cover at the Museum of Comparative Zoology at Harvard University for confirming the identification of the *Lasius* species. A special thank you goes to my friends Dr. Rosanna Giordano and Dr. Felipe Soto Adames for their research, academic, and personal advice during my time in graduate school. I thank my former roommates and friends Jose and Juan Carlos for their personal and academic advice. I am thankful of my many friends and family members that have lent unconditional support and guidance during my completion of this degree. A very special thanks goes to my beloved Neela Dey, who has unconditionally offered much encouragement, guidance, and love, and whose support has been much appreciated. This reserach was funded in part by the American Museum of Natural History - Theodore Roosevelt Memorial Fund and by Dr. Sara Helms Cahan and Dr. Patrick O'Grady.

LIST OF TABLES

Table	Page
Table 1. List of species and collection locations included in this study.....	34
Table 2. Primer sets for genes analyzed in this study.....	36
Table 3. Summary of the maximum variation (between subgenera) of eight genes analyzed in this study. Only ANG and COI were variable enough to be phylogenetically informative.....	37
Table 4. Results of Kishino-Hasegawa and Shimodaira-Hasegawa tests comparing the topology of the COI maximum likelihood (ML) gene tree with the topology of the COI Maximum parsimony (MP) gene tree. These trees are not significantly different *P <0.05.....	38
Table 5. Results of Kishino-Hasegawa and Shimodaira-Hasegawa tests comparing the topology of the 40 ingroup taxa COI gene tree with the topologies of a monophyletic species and subgenera constraint tree (Tree 1) and monophyletic species constraint tree (Tree 2). Both constraint trees are significantly different from the ML COI gene tree. *P <0.05.....	39
Table 6. Results of Kishino-Hasegawa and Shimodaira-Hasegawa tests comparing the COI gene tree topology with six constraint trees for species-level monophyly. (a) Key to the constraint trees for the Kishino-Hasegawa and Shimodaira-Hasegawa tests for monophyly of six <i>Lasius</i> species based on COI data. *P <0.05.....	40
Table 7. Results of Kishino-Hasegawa and Shimodaira-Hasegawa tests comparing the ANG gene tree topology with the COI gene tree topology for 29 taxa. *P <0.05.....	41
Table 8. Results of Kishino-Hasegawa and Shimodaira-Hasegawa tests comparing the ANG gene tree topology with five constraint trees for species-level monophyly. (a) Key to the constraint trees for the Kishino-Hasegawa and Shimodaira-Hasegawa tests for monophyly of six <i>Lasius</i> species based on ANG data. *P <0.05.....	42

LIST OF FIGURES

Figure	Page
<p>Figure 1. Wilson's (1955) hypothesis on the subgenera-level relationships in <i>Lasius</i> ants based on morphological characters</p>	43
<p>Figure 2. Hasegawa's (1998) hypothesis on the subgenera-level relationships in <i>Lasius</i> ants based on COI</p>	44
<p>Figure 3. Janda et al.'s (2004) hypothesis on the subgenera-level relationships in <i>Lasius</i> ants based on total evidence</p>	45
<p>Figure 4. Janda et al.'s (2004) hypothesis on the subgenera-level relationships in <i>Lasius</i> ants based on COI/tRNA/COII. E = European samples, N = North American samples</p>	46
<p>Figure 5. Janda et al.'s (2004) hypothesis on the subgenera-level relationships in <i>Lasius</i> ants based on morphology</p>	47
<p>Figure 6. Distribution of <i>Lasius</i> species based on Wilson (1955) and Creighton (1950). Black circles represent collection sites of <i>Lasius</i> during the summers of 2005 and 2006 included in this study (see Table 1 for detailed sight collections). * Little is known about the distribution of <i>Lasius californicus</i>.....</p>	48
<p>Figure 7. Uncorrected pairwise ANG distances partitioned by codon position (83 codons analyzed). Each point represents one pair of taxa appearing in the phylogeny. The Y-axis presents the overall difference for the genetic sequences for that pair. The X-axis represents genetic distance partitioned by the three codon positions</p>	52
<p>Figure 8. Uncorrected pairwise COI distances partitioned by codon position (261 codons analyzed). Each point represents one pair of taxa appearing in the phylogeny. The Y-axis presents the overall difference for the genetic sequences for that pair. The X-axis represents genetic distance partitioned by the three codon positions. All three positions display linearly increasing substitutions that negate evidence of saturation of nucleotide changes in codon position as would be exhibited by an asymptoting curve</p>	53
<p>Figure 9. Single COI gene tree recovered under maximum parsimony analysis</p>	54

Figure 10. Most likely COI gene tree recovered under ML. State locations are indicated next to each taxon (see FIGURE 6 for specific locations). * Indicate samples that were collected on the outer limits of the species range. Vertical colored bars indicate subgenera (See key)55

Figure 11. Bayesian consensus tree based on COI for 28 taxa. Posterior probabilities are shown above the branches57

Figure 12. Bayesian consensus tree based on ANG for 28 taxa. Posterior probabilities are shown above the branches58

Figure 13. Bayesian consensus tree based on combined data (ANG + COI) for 28 taxa. Posterior probabilities are shown above the branches59

1.1 INTRODUCTION

The ant genus *Lasius* (Formicinae) arose during the early Tertiary approximately 65 million years ago (Wilson 1955; Moreau et al. 2006). *Lasius* is one of the most abundant and widely distributed ant genera in the Holarctic region, with 95 described species placed in six subgenera: *Acanthomyops*, *Austrolasius*, *Cautolasius*, *Chthonolasius*, *Dendrolasius* and *Lasius* (Wilson 1955; Ward 2005).

Species of *Lasius* have been central to numerous species-level studies and the focus of many ecological, agricultural, and behavioral investigations (Holldobler and Wilson 1990; Sakata 1995; Sommer and Holldobler 1995). This work has revealed abundant interspecific variation in a variety of behavioral and ecological characteristics, which suggest that the genus could serve as a valuable model system for understanding the evolution of fundamental social traits (Janda et al. 2004). Such traits include temporary social parasitism, subterranean habits, queen number, mating frequency, and tending of phytophagous insects (Creighton 1950; Holldobler and Wilson 1990; Fjerdingstad 2002; Janda et al. 2004; Ward 2005).

Morphological evolution of this genus is equally as interesting because there is variation in the rates of evolution of morphological characters across subgenera and species. For instance, all species of *Cautolasius* have very small eyes containing 6 or fewer ommatidia, while members of *Chthonolasius* have larger eyes with no fewer than 35 ommatidia, and members of the subgenus *Lasius* have the largest eyes, containing tens to hundreds of ommatidia. It is unclear whether variation in eye size is due to differing rates of evolution of this character in these groups or a sign of morphological

convergence due to parallel adaptation to life underground. There is variation in traits within subgenera as well. For instance, two species in the subgenus *Lasius*, *L. pallitarsis* and *L. neoniger*, vary in mandible tooth shape. *Lasius pallitarsis* has an acute apical tooth with a well-defined offset basal angle, while *L. neoniger* has a rounded basal portion of the mandible lacking an off set tooth. In this subgenus, variation is seen not only in the shape of the mandible but also in the number of teeth, eye size, and cuticular surface pilosity. In *Chthonolasius*, worker body size, body coloration, and hair size relative to tibia and gastric tergite size varies among the four species; *L. umbratus*, *L. subumbratus*, *L. minutus*, and *L. vestitus*. In contrast, some species have exhibited very little morphological evolution. For instance, in the subgenus *Lasius*, fossils of extinct *L. schiefferdeckeri* from Baltic amber show very little variation from extant *L. alienus* and *L. niger* (Wilson 1955). This observation is interesting because little morphological change has occurred over millions of years in these species, which may suggest that morphological characters themselves might fail to distinguish evolutionarily independent taxa in some groups. In such cases, methods such as the analysis of molecular data (DNA, amino acids) may be more useful, especially where taxa with generalized morphology are included. For example based on morphology, the hypothetical "prototype" *L. pallitarsis* seems to be intermediary between *L. schiefferdeckeri* and more derived species (Wilson 1955; Janda et al. 2004) but DNA sequence data places *L. pallitarsis* in a position that confounds the monophyly of this subgenus (Janda et al. 2004).

Reconstructing behavioral and morphological evolution within *Lasius* requires a well-resolved phylogeny. However, little attention has been given toward understanding subgeneric and species-level evolutionary relationships in this genus, and the few studies that have been conducted have yielded conflicting results. To date, three studies have addressed questions about relationships within *Lasius*.

E.O. Wilson (1955) attempted to reconstruct the relationships between the subgenera using morphological characters in his revision of the genus. He grouped *Acanthomyops* with *Chthonolasius* and placed *Dendrolasius* basal to *Lasius* + *Cautolasius* (Figure 1). This grouping suggested that a reduction in eye size and color pigmentation associated with subterranean habits occurred twice, once in the *Acanthomyops* + *Chthonolasius* clade and again in *Cautolasius*, with members of the subgenus *Lasius* retaining large eyes and dark pigmentation (Figure 1). This study was also the first attempt to explain the mode of speciation in *Lasius*. Wilson describes *Lasius* as having undergone allopatric speciation, where ancient populations became geographically isolated and subsequently diverged into reproductively isolated groups. Given the distribution and intraspecific variation of *Lasius* species, Wilson argued that all the necessary stages expected for geographic speciation in *Lasius* have occurred. These patterns include barely detectable geographic variation (pilosity and body color in *L. pallitarsis* and eye size in *L. umbratus*), stronger geographic variation resulting in subspecies patterns (pilosity in *L. niger* and *L. fuliginosus*), very strong geographic variation resulting in differences between terminal populations (eye size and appendage polymorphism in *L. flavus*), populations representing distinct morphospecies that replace

one another geographically (*L. emarginatus* and *L. productus*), and sympatry of closely related species with ecological displacement (*L. nearticus* and *L. flavus*).

In 1998, Hasegawa attempted to reconstruct relationships among subgenera in *Lasius* (*Acanthomyops* was not sampled) using 974 base pairs (bp) of cytochrome oxidase I (COI). His analysis suggested a somewhat different set of relationships at the subgeneric level (Figure 2). Hasegawa found *Chthonolasius* rather than *Dendrolasius* to be more closely related to the *Cautolasius* + *Lasius* clade, rather than the two independent derivations of the subterranean habit suggested by Wilson (1955). This COI phylogeny suggests a single origin of the subterranean habit in the ancestor of the subgenera *Dendrolasius*, *Chthonolasius*, *Cautolasius*, and *Lasius*. This trait was either maintained as polymorphic in the ancestors of the present-day subgenera or lost in the subgenus *Lasius*.

In 2004, Janda et al. combined 568 bp of mitochondrial DNA (210 bp of COI, 302 bp of COII, and 56 bp of tRNA-Leu) with morphological characters to reconstruct species-level and subgeneric relationships within the ant tribe Lasiini (Figure 3). Their molecular results differed from both previous analyses, placing *Dendrolasius* as most closely related to *Acanthomyops*, while the European species of *Lasius* formed a moderately well supported clade basal to the remaining subgenera, whose relationships could not be resolved. The results from their analysis of the molecular data suggested that the subgenus *Lasius* is not monophyletic, as the North American *L. pallitarsis* grouped with *Cautolasius* and the *Acanthomyops* + *Dendrolasius* clade (Figure 4). Moreover, results from the analysis of the morphological dataset were incongruent with

the molecular data, particularly concerning the monophyly of *Lasius* and the placement of the subgenus *Chthonolasius* (within or sister to the *Acanthomyops* + *Dendrolasius* clade). Morphological data also failed to support the monophyly of *Chthonolasius* was also not supported by the morphological data (Figure 5).

Studies thus far have demonstrated the difficulty of reconstructing the evolutionary relationships in the genus *Lasius*, difficulties that might be attributed to incongruence in data (morphological versus molecular), limitations in taxon sampling (lacking data for particular taxa), and sampling bias (North America versus Europe and Asia). Although Hasegawa (1998) and Janda et al. (2004) both utilized rigorous and statistical phylogenetic methods (i.e., parsimony, likelihood, Bremer support indices, and bootstrapping) and outgroup analyses, Hasegawa used very few taxa, and Janda et al. had a relatively small molecular data set. In addition, both studies may have sampling methods that were potentially problematic in understanding the species-level and subgeneric relationships in *Lasius*.

The possibility that one or more of the *Lasius* subgenera may not be monophyletic implies that taxon sampling in each subgenus may have profound effects on the resulting tree topology. For instance, Hasegawa used only one species to represent each subgenus, *L. niger* (*L.*), *L. flavus* (*Ca.*), *L. meridionalis* (*Ch.*), and *L. spathepus* (*D.*) hence his study, reveals nothing about monophyly of the subgenera. If a species chosen to represent a subgenus were not actually a member of the same monophyletic group as other members of the subgenus, the placement of the subgenus would be misrepresented.

Janda et al. (2004) used multiple species for some subgenera and single species for others. In their analysis of the molecular data, *Cautolasius*, *Dendrolasius*, and *Acanthomyops* were represented by single species (*L. flavus*, *L. fuliginosus*, and *L. californicus*, respectively). *Chthonolasius* was represented by four species (*L. umbratus*, *L. meridionalis*, *L. distinguendus*, and *L. jensi*) and *Lasius* was represented by five species (*L. pallitarsis*, *L. brunneus*, *L. emarginatus*, *L. alienus*, and *L. psammophilus*). Only two species were included in all three studies, *L. flavus* (*Cautolasius*) and *L. meridionalis* (*Chthonolasius*).

Another potential complicating factor is that the wide geographic distribution of *Lasius* may make it difficult to reconstruct the phylogeny of the group due to the effect of local processes such as cryptic speciation or reticulation. Such processes would make the sampling locations of particular taxonomic groups critical in inferring phylogenetic relationships. Indeed, the striking geographic differences in sampling between Hasegawa and Janda et al.'s studies may be the most significant factor in the differences in relationships seen between these two hypotheses. Representatives of the subgenera in Hasegawa's study were all sampled from Japan except for *L. niger* (subgenus *Lasius*) from Spain. Janda et al. sampled *Cautolasius* and *Acanthomyops* from the western United States, *Chthonolasius* from Europe, and *Lasius* primarily from Europe and Asia. The single *Lasius* representative from North America, *L. pallitarsis*, gave a very different picture of the placement of this subgenus. The placement on a phylogenetic tree of one or multiple nominal species with other species rather than conspecifics may be evidence for cryptic speciation. The placement of different species in close geographical

proximity with each other rather than with geographically separated conspecifics may be evidence for local hybridization or lateral gene transfer.

Sampling bias may also extend to individual species. Many species of *Lasius* have widespread geographic distributions, whereas others are located in small, disjunct populations. For instance *L. alienus* has the widest distribution of any *Lasius* species, extending across Northern North America, Europe, Asia, and the Middle East (Wilson, 1955). In North America there are several species that have relatively wide distributions, including *L. pallitarsis*, *L. neoniger*, *L. flavus*, *L. umbratus*, and *L. claviger*. On the other hand, some species such as *L. arizonicus* and *L. nearcticus* are found only in restricted areas in the southwest United States and northeast United States respectively. Other species with narrow North American distributions include *L. arizonicus*, *L. crypticus*, *L. californicus*, and *L. sitiens*. Sampling species with widespread distributions may be more problematic in terms of phylogenetic inference because such species are exposed to numerous different environmental influences (habitat variation, competition, character displacement, cline effect, etc.). These influences may result in higher degrees of morphological differentiation across the species range. Given the diversity in geographic distributions (widespread versus isolated) of *Lasius* species, morphological characters alone may not be adequate in attempting to understand species-level and subgenus-level evolutionary relationships. These characters may underestimate the true number of species within the genus, adding to the importance of using molecular markers.

Here, I present a molecular phylogeny of North American *Lasius* species representing all North American subgenera, sampled from a contiguous geographical area

across the entire northeastern, north, central, and western United States, to elucidate, subgeneric and species-level evolutionary relationships. There are 33 described extant species in North America in four of the six subgenera (*Acanthomyops*, *Cautolasius*, *Chthonolasius*, and *Lasius*) ranging from northern Mexico to northern Canada (Bolton 1995; Ward 2005). Members of *Acanthomyops* and *Cautolasius* are exclusively subterranean, while members of *Chthonolasius* and *Lasius* forage above ground (Wilson 1955).

The focus of this paper is to use molecular phylogenetic analysis to address questions about the evolutionary relationships of North American *Lasius* species and subgenera and to better understand the biological and evolutionary complexities associated with these species given their North American distributions. By intensively sampling exclusively in North America, it may be possible to get a clear picture of how these species and subgenera are related across their New World range and to begin to understand some of the biological processes that have acted upon *Lasius* species in this region. The phylogenetic hypotheses presented here are based on data from 784 base pairs of COI and 251 base pairs of an anonymous nuclear gene (ANG). Parsimony and likelihood analyses were used along with explicit hypothesis testing using Shimodaira-Hasegawa (SH) tests (Shimodaira and Hasegawa, 1999) to assess the monophyly of subgenera and species, test previous hypotheses (Figures 1 - 5) of these taxonomic relationships, and explore alternative phylogenetic placements.

1.2 METHODS

Taxon sampling and characters analyzed

During the summers of 2005 and 2006, 12 *Lasius* species and one outgroup species were collected from 45 locations (451 colonies) within the United States (Figure 6 and Table 1). Three species of *Acanthomyops*, two species of *Cautolasius*, one species of *Chthonolasius*, and six species of *Lasius* were included in this study. At each location 20-40 individuals were collected from 5-10 colonies per species within a 2-mile radius. Specimens were stored in 85% ethanol and were identified to species using Wilson's (1955) key to *Lasius*. The identification all species were confirmed by Stefan Cover at the Museum of Comparative Zoology at Harvard University. All voucher specimens were deposited at the Zaddock Thompson Natural History Museum at the University of Vermont (Burlington, VT).

Total genomic DNA was extracted from 1-2 whole workers per location using a standard DNeasy Tissue Kit (Qiagen) or 5% Chelex. The partial 5 prime end of the mitochondrial gene cytochrome oxidase I (784 base pairs) was amplified in 12 *Lasius* species and one outgroup species from 41 colonies (Table 1). These data overlapped with 206 bp of Janda et al.'s (2004) COI data and 513 bp of Hasegawa's (1998) COI data. Six known nuclear genes: 28S (956 bp), Wingless (366 bp), Ef-1-Alpha (843 bp), Abdominal-A (642 bp), Arginine-K (440 bp), and Long range rhodopsin (519 bp) were amplified for representatives of four subgenera. Each of these nuclear genes was screened for pairwise differences using PAUP* 4.0b (Swofford 2002); for primer sets see

Table 2.

Primers for the nuclear gene Flightin (F. Soto Adames, pers. comm., May 1, 2006) were designed based on the alignment of 48 hexapods and crustaceans and were used in attempt to amplify a short (156 bp) conserved region of the Flightin gene in *Lasius*. The use of these primers resulted in multiple bands of unexpected size (200 - 1500 bp) in *L. flavus* and *L. pallitarsis*. DNA from a band of approximately 500 base pairs was gel extracted using a standard Qiagen Gel Extraction Kit (Qiagen) and sequenced. Based on these sequences, internal primers were designed to amplify a 251 base pair region in *Lasius*. This 251 bp region was compared to all known nucleotide data using The National Center for Biotechnology Information (NCBI) nucleotide BlastN function with no significant similarities. Based on the conservation and alignment of this region across *Lasius* species, an 83 amino acid long open reading frame, and a bias towards mostly 3rd codon substitutions (Figure 8), this region is thought to be an anonymous nuclear gene (ANG). Of all the nuclear genes sampled here, ANG was the only candidate with enough variability (Table 3) to be phylogenetically informative.

An attempt was made to amplify ANG in all 41 taxa. This gene could only be amplified in nine *Lasius* species and one outgroup species from 28 colonies. Polymerase chain reaction (PCR) amplifications were performed in 20 µl reactions: 2 µl *Invitrogen* 10X PCR reaction buffer, 1.5 µl dNTPs, 0.8 µl 50 mM MgCl₂, 1.0 µl, Forward primer (10 µM), 1.0 µl Reverse primer (10 µM), 9.6 µl ddH₂O, 0.10 µl *Invitrogen* Taq DNA polymerase, and 4.0 µl template DNA. All reactions were performed under the following temperature regime using an *Eppendorf Mastercycler* thermocycler: 95° C for 1 min, (95°

C for 1 min, 50° C for 30 sec, 72° C for 1 min) X 35 with a final extension of 72° C for 10 min. PCR products were purified using USB ExoSap-IT reactions as specified by the manufacturer (USB, Cleveland, OH). Sequencing was performed on an ABI 3100 automated sequencer at the Vermont Cancer Center Sequencing Facility at the University of Vermont (Burlington, VT). This same PCR and sequencing protocol was employed for COI.

Phylogenetic analyses

DNA sequences were aligned by eye using MacClade (Maddison and Maddison 2005). Phylogenetic analyses were performed using PAUP (Swofford 2002) and Mr. Bayes v3.0b4 (Huelsenbeck and Ronquist 2005). Model Test v3.7 (Posada and Crandall 1998) was used to determine the most likely model of evolution for the data set. A maximum parsimony analysis was performed using 1,000 random sequence additions and a tree-bisection-reconnection swapping algorithm. A maximum likelihood analysis was employed using a general time reversal model (GTR + I + G) and a heuristic search with 500 replicates. Bootstrap (Felsenstein 1985) support values were generated for both maximum parsimony (1,000 replicates) and maximum likelihood (200 replicates) analyses. A Bayesian analysis was conducted using the GTR + I + G in Mr. Bayes. This analysis was run with 1,000,000 generations; samples were taken every 1,000 generations. The burn-in was set to 200. Resulting tree topologies from these analyses were tested against several alternative constraint topologies using Kishino-Hasegawa and

Shimodaira-Hasegawa (Kishino and Hasegawa 1989) log-likelihood tests for monophyletic subgenera and species.

1.3 RESULTS

Altogether, eight genes were analyzed. Of these, only COI and ANG were variable enough to be phylogenetically informative (Table 3). The 784 base pairs of COI sequences were highly A-T rich (mean = 73.087% excluding *P. imparis*). This is not unusual for mitochondrial genes in Hymenoptera (Simon et al. 1994). This A-T rich bias was homogeneous across all 40 ingroup taxa (Chi-square test of base homogeneity = 17.601, $P = 1.000$). Uncorrected (P) distances for this gene between all ingroup taxa ranged from 0.25% - 19.95%. This relatively small amount of sequence divergence in a group that arose 65 million years ago and has species that are thought to have separated during the Oligocene (33.7 - 23.8 mya) may suggest saturation, however this possibility was rejected using a standard test of saturation (Figure 8).

Cytochrome Oxidase I

The resulting trees for COI from the maximum parsimony and maximum likelihood analyses can be seen in Figures 9 and 10. These trees are not significantly different based on the results of the comparison of the tree topologies using Kishino-Hasegawa and Shimodaira-Hasegawa log likelihood ratio tests ($P = 0.3150$, Table 4).

Therefore all further discussions of the COI tree will refer to the maximum likelihood tree (Figure 10).

Figure 10 shows the maximum likelihood tree for COI with colored bars indicating subgenera. The geographic location where each colony was sampled is placed next to each terminal taxon. The results of the Kishino-Hasegawa and Shimodaira-Hasegawa log likelihood ratio tests for comparison of this tree with constraint trees for monophyletic subgenera and species implies that neither taxonomic level is monophyletic (Tables 5 and 6). Many taxa confound the monophyly of the species on this tree. These include *L. alienus*, *L. flavus*, *L. nearcticus*, *L. pallitarsis*, *L. umbratus*, and members of *Acanthomyops*.

Lasius alienus

Altogether, four *L. alienus* colonies were sampled from Ohio, Michigan, and Arizona. The placement of each *L. alienus* colony on the tree is highly supported. The two colonies sampled from Ohio are placed together, while the sample from Michigan is basal to these. The *L. alienus* sampled from Arizona is placed within a second clade including all western *Lasius* taxa and next to *L. crypticus* sampled from Washington (Figure 10).

Lasius flavus and *L. nearcticus*

There were three colonies of *L. flavus* sampled from New York, Illinois, and California and three colonies of *L. nearcticus* sampled from New York, Pennsylvania, and Vermont. The majority of these *Cautolasius* (two *L. flavus* and three *L. nearcticus*) are placed in the same clade and one *L. flavus* is placed outside of this clade. Inside the *Cautolasius* clade, the haplotypes are intermixed. The *L. nearcticus* from Pennsylvania and Vermont are placed together and basal to the remaining representatives where the *L. flavus* from California is placed closer to the *L. nearcticus* from New York rather than the expected *L. flavus* from New York. The remaining *L. flavus* sampled from Illinois is placed inside a predominantly *Chthonolasius* clade and next to an *L. umbratus* sampled from Indiana (Figure 10).

Lasius pallitarsis

There were six colonies of *L. pallitarsis* sampled from New Mexico, Arizona, California, Colorado, and Washington (Figure 10). The placements of all *L. pallitarsis* samples on the tree were highly supported. Most of the colonies were in the same clade and with *L. umbratus*. In this clade, the *L. pallitarsis* sampled from the mountains of western California was sister to the sample from Arizona, while the *L. pallitarsis* sampled from eastern coastal California grouped with the sample from Washington and next to two *L. umbratus* colonies sampled from eastern California. The colony sampled from Colorado grouped with a *L. neoniger* colony sampled from Vermont and basal to the remaining *L. pallitarsis* in this clade. Outside of this clade, one *L. pallitarsis* sampled

from New Mexico was placed within a *Lasius* clade and sister to *L. niger* sampled from Washington.

Lasius umbratus

There were 11 colonies of *L. umbratus* sampled from seven states a colony from California, Arizona, Illinois, Indiana, Ohio, Pennsylvania, and Vermont. The *L. umbratus* sampled in this study represent the subgenus *Chthonolasius* and the placement of each of these is highly supported. The *L. umbratus* sampled from Arizona, Indiana, Ohio and Vermont were all placed in the same clade. The *L. umbratus* sampled from Illinois is placed within the *Acanthomyops* clade and next to *L. claviger* sampled from Michigan. The three *L. umbratus* colonies sampled from California were placed in the same clade with samples of *L. pallitarsis* sampled from the western United States (see previous section). The single *L. umbratus* colony sampled from Pennsylvania was placed in a basal position within the *L. alienus* clade (Figure 10)

Acanthomyops

There were three species of *Acanthomyops* included in this study, *L. claviger* sampled from New York and Michigan, *L. arizonicus* sampled from Arizona, and *L. californicus* sampled from California. All three species were placed in the same clade and highly supported. The *L. arizonicus* and *L. californicus* were placed together while

the *L. claviger* sampled from Michigan was placed next to the *L. umbratus* sampled from Illinois, and the *L. claviger* was placed in a position basal to the remaining species in this clade (Figure 10).

Anonymous Nuclear Gene

More than half (68 %) of the specimens analyzed using COI could be amplified for ANG. Of these, 83 % of *Cautolasius*, 94 % of *Lasius*, 45 % of *Chthonolasius*, and none of the *Acanthomyops* amplified for ANG. The Bayesian consensus trees of these 28 taxa for COI and ANG can be seen in Figures 11 and 12. These trees are significantly different based on the results of the comparison of the tree topologies using Kishino-Hasegawa and Shimodaira-Hasegawa log likelihood ratio tests ($P < 0.00001$, Table 7). The resulting ANG consensus tree is mostly unresolved while the COI consensus tree is highly resolved. Kishino-Hasegawa and Shimodaira-Hasegawa log likelihood ratio tests were used to compare the ANG consensus tree to that of constraint trees for monophyletic subgenera and species. Each constraint tree was significantly different than the ANG consensus tree (Table 8).

The eastern *L. alienus* sampled from Ohio and Michigan are placed in the same clade, while the *L. alienus* sampled from Arizona is placed with other western *Lasius* representatives including *L. crypticus* sampled from Washington. All of the *L. neoniger* were placed in an unresolved clade sister to the eastern *L. alienus* clade. All but one *L. pallitarsis* were placed in an unresolved clade with all of the *L. umbratus* and most of the

Cautolasius. The *L. pallitarsis* sampled from New Mexico was placed in the western *Lasius* clade that included the *L. niger* sampled from Washington. The *L. flavus* sampled from California was placed in the unresolved clade including *L. umbratus* and *L. pallitarsis* and next to one of the *L. nearcticus* sampled from New York. The remaining *L. flavus* sampled from New York was basal to all the ingroup species (Figure 12). The placement of the species on the COI consensus tree for the 28 taxa were very similar to that of the placement of these species on the 41 taxa COI tree (Figures 10, 12 and 13).

1.4 DISCUSSION

The purpose of this study was to use phylogenetic analysis of mitochondrial and nuclear sequence data to investigate how North American *Lasius* species and subgenera are related. The analysis of COI and ANG together and separately did not result in trees with monophyletic species or subgenera. The hypothesis generated from a maximum likelihood analysis of 41 taxa based on COI resulted in the unexpected placement of some species on the tree. Problematic species include *L. alienus*, *L. pallitarsis*, *L. flavus*, and *L. umbratus*.

Most of the *L. alienus* and *L. pallitarsis* colonies sampled were placed together in separate clades, however both species have at least one colony that was placed in an unexpected position. The *L. alienus* sampled from Ohio and Michigan were placed in the same clade with a basal *L. umbratus* sampled from Pennsylvania. The *L. alienus* sampled from Arizona was placed in a separate clade including members of the subgenus *Lasius* and next to the *L. crypticus* sampled from Washington. Most of the *L. pallitarsis* were

placed in a clade with *L. umbratus*, however the sample from New Mexico was placed in the same clade as the *L. alienus* sampled from Arizona and next to *L. niger* from Washington.

In this study, the subgenus *Cautolasius* is represented by *L. flavus* and *L. nearcticus*. The *L. flavus* sampled from New York and California were placed in a clade with the *L. nearcticus* sampled New York, Pennsylvania, and Vermont. The *L. flavus* colony sampled from Illinois was placed in a derived position within the *L. umbratus* clade.

Lasius umbratus represents the subgenus *Chthonolasius* in this study and has the widest geographic distribution of the North America *Lasius* species. This species is nested within and basal to the *L. pallitarsis* clade, basal to the *L. alienus* clade, and placed within the *Acanthomyops* clade.

All of the *Acanthomyops* species sampled in this study were placed in the same clade based on the COI dataset. The *L. claviger* sampled from New York was placed in a basal position in this clade, while the *L. claviger* sampled from Michigan was placed next to the *L. umbratus* sampled from Illinois.

More than half of the samples analyzed (28 taxa) using COI could be amplified for ANG. None of the members of the subgenus *Acanthomyops* could be amplified for ANG. The Bayesian likelihood analyses of these 28 taxa based on ANG and COI + ANG resulted in partially unresolved trees with unexpected placement of the taxa similar to that of the COI tree alone.

Although molecular data may be extremely useful when studying taxa with little morphological variation, it can also generate complex phylogenetic patterns that are difficult to interpret. The hypotheses generated in this study from the analyses of COI and ANG produced unexpected patterns of phylogenetic placement of *Lasius* species and subgenera that exemplify this problem. A number of biological processes alone or together could in part explain these patterns, including interspecific hybridization, gene introgression, incomplete lineage sorting, and the presence of multiple cryptic species in this study set.

Interspecific hybridization

Interspecific hybridization can be problematic for interpreting the results of a phylogenetic analysis. If a gene transfer event resulting from hybridization has occurred between two species, then sampling this gene may render seemingly strange and unexpected patterns of placement of these taxa on a tree. Furthermore, one can expect discordance between morphological and molecular characters in a system with interspecific hybridization. Although rare, hybrid speciation has been documented in insects (Mavárez et al. 2006) and this could pose a major problem in interpreting results if such hybrid daughter-species were sampled.

Interspecific hybridization has been well documented in many taxa including ants (Bechtel and Mountain 1960; Schwenk et al. 2004; Nonacs 2006). In North America, morphological hybrids of the fire ants *S. geminata* and *S. xyloni* have been described in

Texas (Helms Cahan and Vinson 2003) and hybrid zones of Harvester ants (*Pogonomrymex*) have been identified in Arizona (Helms Cahan and Keller 2003). Ross and Shoemaker (2005) analyzed South American fire ants using mitochondrial and nuclear markers to demonstrate evidence of horizontal gene transfer. The results of their study suggest that two species of *Solenopsis*, *S. invicta* and *S. richteri*, have introgressed into *S. quinquecupis*. Mismatching mtDNA haplotypes have been used to demonstrate that hybridization occurs in more than 65% of West Palaearctic wood ants in the genus *Formica*. There is evidence that up to 10% of ant species hybridize, including members of the genus *Lasius* (Seifert 1999).

Interspecific hybridization has been documented in a number of *Lasius* species. Pearson (1983) has demonstrated that patterns of allozyme frequencies in intermediates of European *Lasius niger* and *L. alienus* suggest that they are hybrid forms. Hybridization between two North American *Lasius* species, *L. claviger* and *L. latipes* (subgenus *Acanthomyops*) has been well documented based on morphology (Wing 1968) and evidence from isozyme electrophoresis (Umphrey and Danzmann 1998).

Given the species richness of the genus *Lasius* and the numerous examples of interspecific hybridization in *Lasius* and other ant taxa, it is not unreasonable to expect that it may occur in North American *Lasius* species. The patterns observed on the trees presented here (Figures 10 and 11-13) could suggest some historical gene flow has occurred between some species of *Lasius* in North America with interspecific hybridization being one possible explanation. Spatially varying processes should affect wide ranging species more than narrow ranging species. It is expected to see more

evidence for reticulation at species and habitat boundaries. In this study, *L. umbratus* is the most problematic species and has the widest geographically sampled range. Figure 10 shows sample collection sites on the tree.

At the limit of a species' range, the density of individuals of that species (or colonies in this case) may be significantly smaller than in their native range, as is the case with *L. alienus* (Wilson 1955). Bolnick (2001) has shown that interspecific hybridization can result in niche width expansion, allowing a species to increase its ecological niche when intraspecific competition for nest sites is high. Therefore conspecific colonies in sympatry with a species on its outer limit, and thus locally rare, may benefit from interspecific hybridization with that species. Interspecific hybridization may be adaptive in this scenario at the colony level. Figures 11-13 show that *L. alienus* from Arizona groups with *L. crypticus* from Washington rather than with the expected three Ohio *L. alienus* specimens. The Arizona specimen was collected from the outer limit of the species range, which may also suggest local historical hybridization with other closely related species in close geographic proximity. Similar patterns are seen in the placement of *L. pallitarsis* and *L. umbratus* (Figure 10). Horizontal gene transfer could also explain the case where the single *L. flavus* groups in the *umbratus* clade (Figure 10). It is possible that *L. flavus* and *L. nearcticus* are actually not separate species.

Incongruence between the phylogenetic placement of taxa on both the COI tree and ANG tree (Figures 11 and 12) may also suggest horizontal gene transfer has occurred in some species as a result of interspecific hybridization. This is the case in the beetle genus *Carabus*, where there is evidence that incongruence between nuclear and

mitochondrial gene trees may have been promoted by geographic isolation and interspecific hybridization. Comparison of gene trees in *Carabus* has also been used to identify reticulate patterns in species with extremely divergent morphological structures (Sota and Vogler 2001). Gomez-Zurita and Vogler (2003) show that incongruence of trees from analyses of multiple independent genes indicates hybridization in the *Timarcha goettingensis* species complex (Coleoptera, Chysomelidae). In the present study, incongruence between the ANG and COI trees may indicate similar patterns of hybridization in *L. neoniger* with *L. pallitarsis*. In the ANG tree (Figure 12), all the *L. neoniger* are monophyletic and highly supported, whereas in the COI tree (Figure 11) a single *L. neoniger* is placed within the *L. pallitarsis* + *L. umbratus* clade.

There are some benefits to ant colonies that contain interspecific hybrids and this could account for the possible high frequency of hybridization in the genus *Lasius*. For instance *L. latipes* (*Acanthomyops*) is specialized with respect to habitat preference, while *L. claviger* is more generalized. Hybrid colonies of these species tend to be more moisture tolerant in nest founding and outcompete pure *L. latipes* colonies in sympatry (Talbot 1973). Furthermore, hybrid workers presumably have higher levels of heterozygosity resulting in hybrid vigor and thus may be less susceptible to parasites and disease (Burke and Arnold 2001). Using a model of selection for sperm parasitism, Umphrey (2006) showed that selection could favor interspecific mating in ants. North America contains many habitats ranging from the dense moist forests of the northeast and northwest to the dry arid deserts of the southwest and the semi dry prairies of the Midwest; *Lasius umbratus* occupies each of these habitats. The data from this study

suggests that there may be hybridization between *L. umbratus* and *L. alienus*, *L. pallitarsis*, and *L. flavus*. It is not impossible that *L. umbratus* colonies that occupy very different habitats across their range could benefit from hybridizing with species that are specialized to these habitats such as *L. alienus*, which is limited by the deciduous forest.

Cryptic species

Sampling genetically isolated populations could result in unusual or unexpected placement of taxa on a tree. Such resulting trees could be interpreted as phylogenetic patterns of geographical alliance that cross species boundaries but they could also indicate the presence of cryptic species in the study set. For instance, Copepods with large geographic ranges and very little morphological divergence in isolated populations show patterns of genetic divergence indicating relatively recent cryptic speciation (Lee and Frost 2002). There is evidence of this in South American fire ants in the genus *Solenopsis* as well: Ross and Shoemaker (2005) identified populations of genetically isolated *Solenopsis* species and suggested that these are cryptic species.

It can be expected to see more cases of cryptic speciation in groups with generalized morphology where there are few morphological characters to separate them, as is the case with many members of the genus *Lasius*. In the present study, the *L. alienus* representative from Arizona was collected from what is thought to be the outer limits of its range (Figure 6). This, combined with the unexpected grouping patterns may suggest the presence of previously unrecognized or cryptic species. A similar argument

can be made for the *L. pallitarsis* and *L. alienus* that group with *L. niger*. In addition, there may be evidence of this in the eastern and western *L. umbratus*, especially because of the lack of amplification of ANG in some of these species. In South American fire ants, the presumed cryptic species are thought to be sister taxa. This is not the case here in North American *Lasius* and may be an example of a case where non-sister taxa are indistinguishable. Nonsister cryptic species have also been identified in the fig wasp family Agaonidae (Molbo et al. 2003)

Incomplete lineage sorting

There is evidence that incomplete lineage sorting can lead to phylogenies with large scale paraphyly and polyphyly, especially in species-rich taxa with large geographic-distributions. The amount of time since divergence plays a major role in the extent of intermixed species (Takahashi et al. 2001; Ross and Shoemaker 2005; Peters et al. 2007). The large scale paraphyly and polyphyly of *L. umbratus* and *L. pallitarsis* seen in the resulting trees in this study (Figures 10, 11-13) could be explained by incomplete lineage sorting in these species: there are sequence differences of 8.2 % - 9.6 % for *L. umbratus* and 4.2 % - 10.6 % for *L. pallitarsis* between outliers and central range samples. The single *L. umbratus* sample from Pennsylvania that groups with *L. alienus* only differs from these by 0.26 % and may be due to horizontal gene transfer. The intermingling of *L. flavus* and *L. nearcticus* could also be explained by incomplete lineage sorting, especially in the case where the western *L. flavus* sample from California separates the two New York *L. nearcticus* (Figure 10). However there is 19.12 %

divergence between the New York *L. nearcticus* and the California *L. flavus* for ANG and only 0.64 % for COI; this does not support incomplete lineage sorting in these particular species.

There is no large scale monophyly of the species or subgenera in this study and the trees presented here are largely discordant with the previously hypothesized relationships, however some generalizations between them can be drawn. For instance Figure 10 shows the most likely tree found under Maximum Likelihood analysis of the COI data; and it suggests that *Acanthomyops* and *Chthonolasius* are most closely related, as is the case with Wilson's 1955 hypothesis. In this study, the Maximum Likelihood analysis of the COI data generated a novel tree (Figure 10) with some similarities to those presented by Janda et al. (2004). As previously stated, *Acanthomyops* and *Chthonolasius* are most closely related and a non-monophyletic *L. pallitarsis* is placed outside of the subgenus *Lasius* and sister to *Acanthomyops* + *Chthonolasius*. These same relationships are suggested by Janda et al. (2004) in their analysis of COI/COII/tRNA-Leu. However, in the present study, *Cautolasius* is placed next to these clades which differs from the results of Janda et al. (2004) where *Cautolasius* is unresolved and placed next to *L. pallitarsis* and in a clade sister to *Chthonolasius*. In the analysis of COI for 41 taxa, the majority of members in the subgenus *Lasius* are basal to all remaining *Lasius* species as is the case with Janda et al. (2004) but in the present study this clade is split into two major groups, a predominantly *L. neoniger* clade and the remaining *Lasius* species.

The primary purpose of this study was to use phylogenetic analysis of ANG and COI sequence data to assess species-level and subgeneric level relationships in North

American *Lasius*. In the 28 taxa combined COI + ANG tree (Figure 13), *Cautolasius* is the only monophyletic subgenus, however no ANG data could be obtained for the single Illinois *L. flavus* sample that confounds the *Cautolasius* monophyly in the COI tree (Figure 10). In the combined data tree (Figure 13), both *Lasius* and *Chthonolasius* are polyphyletic. In the subgenus *Lasius*, both eastern North American *neoniger* and *alienus* group together, and the western North American samples have peculiar patterns of placement. For instance all western *L. pallitarsis* group with all western *L. umbratus* except one *L. pallitarsis* sample from New Mexico which groups with the remaining western *Lasius* species. In *Chthonolasius*, there is a clear split between eastern and western North American *L. umbratus*.

Data considerations

The phylogenetic trees in this study resulted from the analysis of partial sequence data from the mitochondrial gene COI and an anonymous nuclear gene (ANG), about which nothing was known prior to this study. COI is commonly used as a starting point in phylogenetic studies investigating insect taxa (Simon et al. 1994) and has also been considered for molecular bar-coding (Herbert et al. 2003). However, mitochondrial genes such as COI may be problematic and many arguments have been made against using COI for molecular bar-coding. Funk and Omland (2003) suggest that using COI to bar-code recently diverged species that diverged recently may not be appropriate due to large scale polyphyly. In addition, mitochondrial genes are prone to incomplete lineage

sorting (Ross and Shoemaker 2005), interspecific hybridization, and *Wolbachia*-mediated selective sweeps resulting in trans-specific mitochondrial capture events (Shoemaker et al. 2000). In this study, COI and ANG were used because they were variable enough (19.9 % and 26.7 % variation respectively) in *Lasius* to be phylogenetically informative, unlike the six additional nuclear genes sampled. Also, two of the three previous hypotheses of *Lasius* evolutionary relationships were based on COI. Janda et al. 2004 used only a small portion of COI that overlapped with the data used in the present study. The other mitochondrial genes they used, tRNA-Leu and COII, are in close proximity to COI and should have similar evolutionary trajectories. It is interesting that the study of Janda et al. (2004) did not result in large-scale patterns of paraphyly and polyphyly as was the case in the present work. However, they do have two problematic *Chthonolasius* taxa as well as the issue of *L. pallitarsis*. Even though they did not use multiple representatives of the same species, if the genes they used had a similar evolution to the North American ones, then jumping of species across subgenus boundaries in European and Asian *Lasius* could also be expected. Given similarities in the widespread distribution of European and Asian *Lasius*, it is possible that these same patterns would occur in *Lasius* in Europe and Asia if samples from rare species and/or species on the outer limits of their ranges were sampled.

More than half (68%) of the specimens analyzed using COI could be amplified for ANG. Of these, 83% of *Cautolasius*, 94% of *Lasius*, 45% of *Chthonolasius*, and none of the *Acanthomyops*. This is interesting because it indicates something potentially different about ANG in this clade. It is possible that this gene does not exist in these

taxa. The non-amplification in some taxa may be due to single or multiple base pair substitutions in one primer site in these taxa. Caution must be taken with analyses of ANG because this gene has not been identified in any other taxon and may exist in multiple copies.

Conclusions

The hypotheses generated in this study based on the analyses of COI and ANG sequence data suggest that within the genus *Lasius* in North America, the species and subgenera are not monophyletic. Many of these relationships do however concur partially with those of previous studies. For instance, Wilson (1955) suggested that *Acanthomyops* and *Chthonolasius* were most closely related and the resulting COI tree in this study supports his hypothesis. Based on COI data, both this study and Janda et al. (2004) suggest that *Cautolasius* and *Lasius* are not most closely related as suggested by Hasegawa (1998) and Wilson (1955). In addition, Janda et al. (2004) places *L. pallitarsis* outside of the *Lasius* subgenus and the remaining *Lasius* members in a basal position in the genus which concur with the results of the present study based on COI and ANG + COI.

Given the widespread distribution of North American *Lasius* species and the placement of these species on the trees in this study, it is likely that these relationships are indicative of the complex biological processes that have acted on this genus. It could be possible that nominal species with such widespread distribution as *L. umbratus* and *L.*

pallitarsis could actually be multiple species across this range. Some of the patterns on the present trees could indicate the presence of cryptic species. In addition, it is not unlikely that other processes have acted on this genus such as interspecific hybridization and incomplete sorting of gene lineages especially given the relationships based on the hypotheses presented in this study.

Additional sampling of North American *Lasius* species could prove useful to elucidate the specific historical processes that have acted on this genus. Sampling at the population level and focusing on the problematic species seen in this study and employing methods utilizing additional molecular markers such as microsatellites could be an appropriate next step in determining the direction of gene flow if present. Many of the species included in this study were collected outside of their known ranges. Sampling mitochondrial haplotypes throughout the entire United States for each species including the Midwest United States and using nested clade analysis could help to identify recent range expansions, long distance colonization, restricted gene flow, and allopatric fragmentation.

LITERATURE CITED

- Bechtel, H.B., Mountain, J. 1960. Interspecific Hybridization between Two Snakes of the Genus *Elaphe*. *Copeia*. 2, 151-153.
- Bolnick, D.L., 2001. Intraspecific competition favours niche width expansion in *Drosophila melanogaster*. *Nature* 410, 463-466.
- Bolton, B., 1995. *A New General Catalogue of the Ants of the World*. Harvard University Press, Cambridge, MA.
- Burke, J.M., Arnold, M.L. 2001. Genetics and the fitness of hybrids. *Annu. Rev. Genet.* 35, 31-52.
- Creighton, W.S. 1950. The ants of North America. *B. Mus. Comp. Zool.* 104, 1-585.
- Felsenstein, J. 1985. Confidence limits on phylogenies: An approach using the bootstrap. *Evolution*. 39, 783-791.
- Fjerdingstad, E.J., Pia, J., Gertsch, Keller, L. 2002. Why do some social insect queens mate with several males? Testing the sex-ratio manipulation hypothesis in *Lasius niger*. *Evolution*. 56, 553-562.
- Funk, D.J., Omland, K.E. 2003. Species-level paraphyly and polyphyly: Frequency, Causes, and Consequences, with Insights from Animal Mitochondrial DNA. *Annual Review of Ecology, Evolution, and Systematics*. 34, 397-423.
- Gomez-Zurita, J., Vogler, A.P. 2003. Incongruent nuclear and mitochondrial phylogeographic patterns in the *Timarcha goettingensis* species complex (Coleoptera, Chrysomelidae). *J. Evolutionary Biology*. 16, 833-843.
- Hasegawa, E., 1998. Phylogeny and host-parasite relationships in social parasitism in *Lasius* ants. *Entomol. Sci.* 1, 133-135.
- Helms Cahan, S., L. Keller. 2003. Complex hybrid origin of genetic caste determination in harvester ants. *Nature*. 424, 306-309.
- Helms Cahan, S., S. B. Vinson. 2003. Reproductive division of labor between hybrid and nonhybrid offspring in a fire ant hybrid zone. *Evolution*. 57, 1562-1570.
- Hebert, P.N., Cywinska A, Ball S.L., DeWaard, J.R. 2003. Biological identifications through DNA barcodes. *Proceedings of the Royal Society of London. Series B, Biological Sciences*. 270:313-321.

- Hölldobler, B., Wilson, E.O. 1990. *The Ants*. Belknap, Cambridge, MA.
- Huelsenbeck, J.P., Ronquist, F. 2005. Bayesian analysis of molecular evolution using MrBayes. In: Nielsen, R. (ed.), *Statistical Methods in Molecular Evolution*. Springer, New York.
- Janda, M., Folkova, D., Zrzavy, J. 2004. Phylogeny of *Lasius* ants based on mitochondrial DNA and morphology, and the evolution of social parasitism in the *Lasiini* (Hymenoptera: Formicidae). *Molecular Phylogenetics and Evolution*. 33, 595–614.
- Kishino, H., Hasegawa, M. 1989. Evaluation of the maximum likelihood estimate of the evolutionary tree topologies from DNA sequence data, and the branching order of Hominoidea. *Journal of Molecular Evolution*. 29, 170–179.
- Lee, C.E., Frost, B.W. 2002. Morphological stasis in the *Eurytemora affinis* species complex (Copepoda: Temoridae). *Hydrobiologia*. 480, 111-128.
- Maddison, D.R., Maddison, W.P. 2005. *MacClade Version 4.06*. Sinauer Associates, Sunderland, MA.
- Mavárez, J., Salazar, C.A., Bermingham, E., Salcedo, C., Jiggins, C., Linares, M. 2006. Speciation by hybridization in *Heliconius* butterflies. *Nature*. 441, 868-871.
- Molbo, D., Machado, C.A., Sevenster, J.G., Keller, L., Herre, E. 2003. Cryptic species of fig-pollinating wasps: Implications for the evolution of the fig–wasp mutualism, sex allocation, and precision of adaptation. *Proc Natl Acad Sci*. 100. 5867-5872.
- Moreau, C.S., Bell, C.D., Vila, R., Archibald, B., Pierce, N.E. 2006. Phylogeny of the Ants: Diversification in the Age of Angiosperms. *Science*. 312, 101-104.
- Nonacs, P. 2006. Interspecific hybridization in ants: at the intersection of ecology, evolution, and behavior. *Ecology*. 87, 2413-2147.
- Pearson 1983. Hybridization between the ant species *L. niger* and *L. alienus*: the genetic evidence. *Insectes Sociaux*. 30, 402-411.
- Peters, J., Zhuravlev, Y., Fefelov, I., Logie, A., Omland, K.E., 2007. Nuclear loci and coalescent methods support ancient hybridization as cause of mitochondrial paralogy between gadwall and falcated duck (*Anas* spp.). *Evolution*. 61, 1992-2006.
- Posada, D., Crandall, K.A. 1998. Modeltest: Testing the model of DNA substitution. *Bioinformatics*. 14, 817–818.

- Ross, K.G., Shoemaker, D.D. 2005. Species delimitation in native South American fire ants. *Molecular Ecology*. 14, 3419–3438.
- Sakata, H. 1995. Indirect interactions between two aphid species in relation to ant attendance. *Ecological Research*. 14, 329-340.
- Schwenk, K., Bijl, M., Menken, S.B.J. 2004. Experimental interspecific hybridization in *Daphnia*. *Hydrobiologia*. 442, 67-73.
- Seifert, B. 1999. Interspecific hybridisations in natural populations of ants by example of a regional fauna (Hymenoptera, Formicidae). *Insectes Sociaux*. 46, 45–52.
- Shimodaira, H., Hasegawa, M. 1999. Multiple comparisons of log-likelihoods with applications to phylogenetic inference, *Molecular Biology and Evolution*, 16, 1114-1116.
- Shoemaker, D.D., Ross, K.G., Keller, L., Vargo, E.L., Werren, J.H. 2000. *Wolbachia* infections in native and introduced populations of fire ants (*Solenopsis* spp.). *Insect Molecular Biology*. 9, 661-673.
- Simon, C., Frati, F., Beckenbach, A., Crespi, B., Liu, H., Flook, P. 1994. Evolution, weighting, and phylogenetic utility of mitochondrial gene sequences and a compilation of conserved polymerase chain reaction primers. *Ann. Entomol. Soc. Am.* 87, 651-701.
- Sommer, K., Hölldobler, B. 1995. Colony founding by queen association and determinants of reduction in queen number in the ant *Lasius niger*. *Animal Behavior*. 50, 287-294.
- Sota, T., Vogler, A.P. 2001. Incongruence of mitochondrial and nuclear gene trees in the Carabid beetles *Ohomopterus*. *Systematic Biology*. 50, 39-59.
- Swofford, D.L. 2002. PAUP*, Phylogenetic Analysis Using Parsimony (*and other methods), Version 4.0b10. Sinauer Associates, Sunderland, MA.
- Takahashi, K., Terai, Y., Nishida, M., Okada, N. 2001. Phylogenetic relationships and ancient incomplete lineage sorting among cichlid fishes in Lake Tanganyika as revealed by analysis of the insertion of retroposons. *Molecular Biology and Evolution*. 18, 2057-2066.
- Talbot, M. 1973. Five species of the ant genus *Acanthomyops* (Hymenoptera: Formicidae) at the Edwin S. George Reserve in southern Michigan. *Great Lakes Entomologist*. 6, 19–22.

Umphrey, G.J., Danzmann, R.G. 1998. Electrophoretic evidence for hybridization in the Ant Genus *Acanthomyops* (Hymenoptera: Formicidae). *Biochemical Systematics and Ecology*. 26, 431-440.

Umphrey, G.J. 2006 evidence for hybridization in the ant genus *Acanthomyops*. *Biochemical Systematics and Ecology*. 26, 431-440.

Ward, P. S. 2005. A synoptic review of the ants of California (Hymenoptera: Formicidae). *Zootaxa*. 936, 3-68.

Ward, P. S., Downie, D. A. 2005. The ant subfamily Pseudomyrmecinae (Hymenoptera: Formicidae): phylogeny and evolution of big-eyed arboreal ants. *Systematic Entomology* 30, 310-335.

Wilson, E.O., 1955. A monographic revision of the ant genus *Lasius*. *B. Mus. Comp. Zool. Harvard*. 113, 1-201.

Wing, M.W., 1968. Taxonomic revision of the Nearctic genus *Acanthomyops* (Hymenoptera: Formicidae). *Mem. Cornell Univ. Agric. Exp. Stn.* 405, 1-173.

TABLE 1.

List of species and collection locations included in this study.

Species	Subgenus	State	County	Latitude	Longitude	Col. Number
<i>L. alienus</i>	<i>L.</i>	Ohio	Fairfield Co	N39 40 37.0	W82 34 19.6	TM114
		Ohio	Fairfield Co	N39 40 34.8	W82 34 18.7	TM104
		Michigan	Livingston Co	N42 24.548	W83 57.668	TM116
		Arizona	Cochise Co	N31 56.003	W109 15.823	TM07
<i>L. niger</i>	<i>L.</i>	Washington	Yakima Co	N46.83333	W120.85	TM15
<i>L. neoniger</i>	<i>L.</i>	Indiana	Franklin Co	N39 24.681	W85 01.426	TM133
		Vermont	Chittenden Co			BTV2.04
		Vermont	Chittenden Co			TM28
		Vermont	Chittenden Co			TM33
		Michigan	Livingston Co	N42 24.540	W83 57.539	TM116
		Washington	Grant Co	N47.59217	W119.35694	TM13
<i>L. sitiens</i>	<i>L.</i>	Arizona	Cochise Co	N31 53.000	W109 14.000	TM20
<i>L. crypticus</i>	<i>L.</i>	Washington	Grant Co	N47.59217	W119.35694	TM08
<i>L. pallitarsis</i>	<i>L.</i>	New Mexico	McKinley Co	N35 22.061	W108 31.259	TM167
		Colorado	Grand Co	N40 12.431	W105 31.377	TM158
		Washington	Pierce Co	N46.83333	W122.43333	TM16
		California	Nevada Co	N39 26.000	W120 14.000	TM17
		California	Humboldt Co	N40 53.000	W124 09.000	TM19
		Arizona	Cochise Co	N31 53.000	W109 14.000	TM18
<i>L. umbratus</i>	<i>Ch.</i>	California	Stanislaus Co			TM184
		California	Stanislaus Co			TM187
		California	Stanislaus Co			TM188
		Pennsylvania	Erie Co	N42 05.873	W83 01.930	TM139
		Indiana	Franklin Co	N39 26.384	W84 59.695	TM134
		Indiana	Franklin Co	N39 26.505	W84 59.030	TM136
		Arizona	Coconino Co	N35 23.961	W111 45.548	TM23
		Vermont	Chittenden Co			BTV3.01
		Ohio	Fairfield Co	N39 40 45.3	W82 34 44.2	TM102
		Ohio	Fairfield Co	N39 40 39.5	W82 34 27.0	TM112
		Illinois	Champaign Co	N39 59.858	W88 39.558	TM125

TABLE 1. Continued.

<i>L. flavus</i>	Ca.	Illinois	Champaign Co	N39 59.858	W88 39.558	TM124
		New York	Ontario Co	N42 41.881	W77 42.218	TM10
		California	Sierra Co	N39 26.980	W120 13.782	TM189
<i>L. nearcticus</i>	Ca.	Vermont	Chittenden Co			BTV2.03
		Pennsylvania	Erie Co	N46 06.800	W79 59.148	TM142
		New York	Ontario Co	N42 41.881	W77 42.218	TM12
<i>L. claviger</i>	A.	Michigan	Livingston Co	N42 24.944	W83 58.140	TM121
		New York	Ontario Co	N42 41.881	W77 42.218	TM03
<i>L. arizonicus</i>	A.	Arizona	Cochise Co	N31 53.000	W109 14.000	TM01
<i>L. californicus</i>	A.	California	San Bernadino Co	N35 15.000	W115 18.000	TM02
<i>P. imparis</i>		Ohio	Fairfield Co	N39 40 47.7	W82 34 38.1	TM111

TABLE 2.

Primer sets for genes analyzed in this study.

Gene		Primer Sequences (5' to 3')	Source
Arginine-K	ArgK F	GTT GAC CAA GCY TTG GA	Kawakita et al. (2003)
	ArgK R	CGT YTT GGC ATC GTT GTG GTA GAT	Kawakita et al. (2003)
Elongation factor-1-alpha	EF-1alpha F	GGA CAC AGA GAT TTC ATC AAR AA	Kawakita et al. (2003)
	EF-1alpha R	TTG CAA AGC TTC RTG RTG CAT TT	Kawakita et al. (2003)
28S	28S-3318F	CCC CCT GAA TTT AAG CAT AT	Kawakita et al. (2003)
	28S-3706R	TCG GAA GGA ACC AGC TAC TA	Schmitz & Moritz (1994)
Wingless	Wg578F	TGC CAN GTG AAR ACY TGC TGG ATG CG	Ward and Downie (2004)
	Wg1032R	ACY TCG CAG CAC CAR TGG AA	Ward and Downie (2004)
Long range rodopsin	LR143F	GAC AAA GTK CCA CCR GAR ATG CT	Abouheif & Wray (2002)
	LR639R	YTT ACC GRT TCC CCA TCC RAA CA	Abouheif & Wray (2002)
Abdominal-A	AA1182F	CCG GCG ATA TGA GTA CGA AAT TC	Ward and Downie (2004)
	AA1824R	TAG AAY GTG CCG CCG CTG CCA T	Ward and Downie (2004)
Centromere E protein	Fln95F	CCR AAR TTT CTN CAR TAC AAA TA	Soto Adames (2007)
	Fln126R	ACG YTC NGC CCA NGT CTG	Soto Adames (2007)
Cytochrome Oxidase I	2195F	TTG ATT TTT TGG TCA TCC AGA AGT	Simon (1996)
	Fly10A R	AAT GCA CTA ATC TGC CAT ATT AG	Soto Adames (2007)

TABLE 3.

Summary of the maximum variation (between subgenera) of eight genes analyzed in this study. Only ANG and COI were variable enough to be phylogenetically informative.

Gene	Length (bp)	% Max. Variation
28S	956	0.600
Wingless	366	2.186
Ef-1-Alpha	843	1.000
Abdominal-A	642	1.270
Arginine-K	440	1.400
Long range rhodopsin	519	1.156
Anonymous nuclear gene	251	23.153 *
Cytochrome oxidase I	784	19.950 *

TABLE 4.

Results of Kishino-Hasegawa and Shimodaira-Hasegawa tests comparing the topology of the COI maximum likelihood (ML) gene tree with the topology of the COI Maximum parsimony (MP) gene tree. These trees are not significantly different. *P <0.05

			KH-Test	SH-Test
Tree	-ln L	Diff -ln L	P*	P*
ML	3997.807	(best)		
MP	4001.753	3.945	0.315	0.315

TABLE 5.

Results of Kishino-Hasegawa and Shimodaira-Hasegawa tests comparing the topology of the 40 ingroup taxa COI gene tree with the topologies of a monophyletic species and subgenera constraint tree (Tree 1) and monophyletic species constraint tree (Tree 2). Both constraint trees are significantly different from the ML COI gene tree. *P <0.05

			KH-Test	SH-Test
Tree	-ln L	Diff -ln L	P*	P*
ML	4007.059	(best)		
1	5321.078	1314.019	> 0.00001	> 0.00001
2	5568.178	1561.119	> 0.00001	> 0.00001

TABLE 6.

Results of Kishino-Hasegawa and Shimodaira-Hasegawa tests comparing the COI gene tree topology with six constraint trees for species-level monophyly. (a) Key to the constraint trees for the Kishino-Hasegawa and Shimodaira-Hasegawa tests for monophyly of six *Lasius* species based on COI data. *P <0.05

			KH-Test	SH-Test
Tree	-ln L	Diff -ln L	P*	P*
ML	4007.05876	(best)		
1	4178.260	171.201	> 0.00001	> 0.00001
2	43330.885	323.827	> 0.00001	> 0.00001
3	4229.036	221.977	> 0.00001	> 0.00001
4	4106.837	99.778	> 0.00001	> 0.00001
5	4809.418	802.359	> 0.00001	> 0.00001
6	4253.223	246.164	> 0.00001	> 0.00001

a.

Tree #	Taxa constrained to be monophyletic
1	<i>L. neoniger</i>
2	<i>L. pallitarsis</i>
3	<i>L. flavus</i>
4	<i>L. nearcticus</i>
5	<i>L. umbratus</i>
6	<i>L. alienus</i>

TABLE 7.

Results of Kishino-Hasegawa and Shimodaira-Hasegawa tests comparing the ANG gene tree topology with the COI gene tree topology for 29 taxa. *P <0.05

			KH-Test	SH-Test
Tree	-ln L	Diff -ln L	P*	P*
ANG	4275.469	742.368	> 0.00001	> 0.00001
COI	3533.101	(best)		

TABLE 8.

Results of Kishino-Hasegawa and Shimodaira-Hasegawa tests comparing the ANG gene tree topology with five constraint trees for species-level monophyly. (a) Key to the constraint trees for the Kishino-Hasegawa and Shimodaira-Hasegawa tests for monophyly of six *Lasius* species based on ANG data. *P <0.05

			KH-Test	SH-Test
Tree	-ln L	Diff -ln L	P*	P*
ML	4114.445	68.775	> 0.00001	> 0.00001
1	4255.293	209.623	> 0.00001	> 0.00001
2	4138.471	92.801	> 0.00001	> 0.00001
3	4101.703	56.033	> 0.00001	> 0.00001
4	4183.903	138.233	> 0.00001	> 0.00001
5	4124.142	81.472	> 0.00001	> 0.00001
6	4045.670	(best)		

a.

Tree #	Taxa constrained to be monophyletic
1	<i>L. alienus</i>
2	<i>L. flavus</i>
3	<i>L. umbratus</i>
4	<i>L. pallitarsis</i>
5	<i>L. neoniger</i>
6	<i>L. nearcticus</i>

FIGURE 1.

Wilson's (1955) hypothesis on the subgenera-level relationships in *Lasius* ants based on morphological characters.

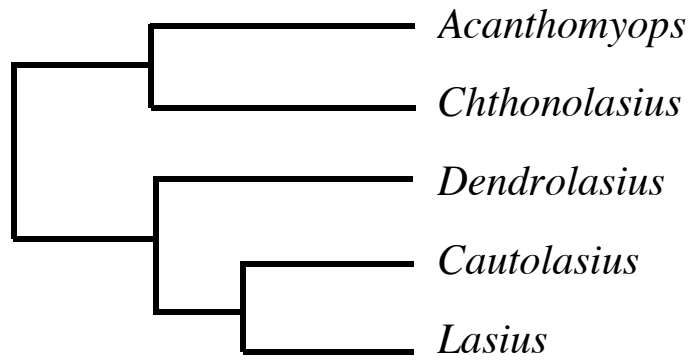

FIGURE 2.

Hasegawa's (1998) hypothesis on the subgenera-level relationships in *Lasius* ants based on COI.

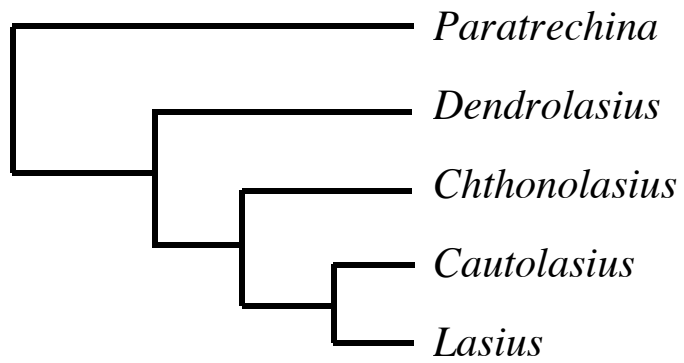

FIGURE 3.

Janda et al.'s (2004) hypothesis on the subgenera-level relationships in *Lasius* ants based on total evidence.

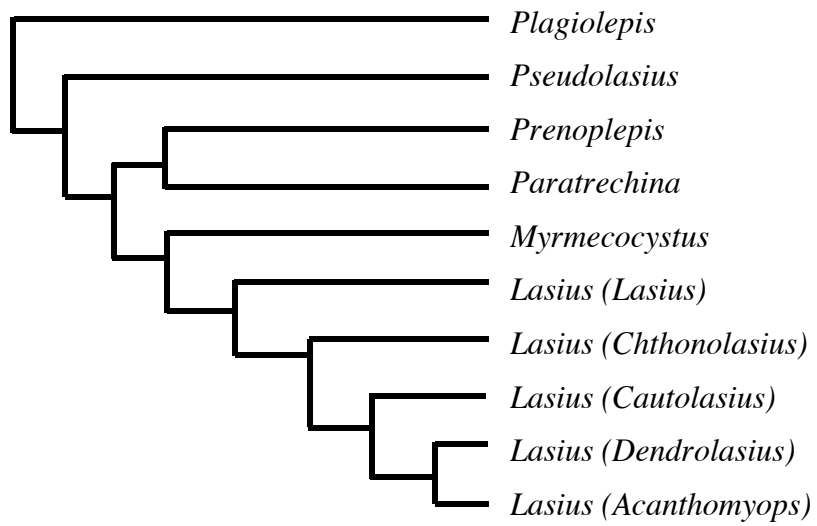

FIGURE 4.

Janda et al.'s (2004) hypothesis on the subgenera-level relationships in *Lasius* ants based on COI/tRNA/COII. E = European samples, N = North American samples.

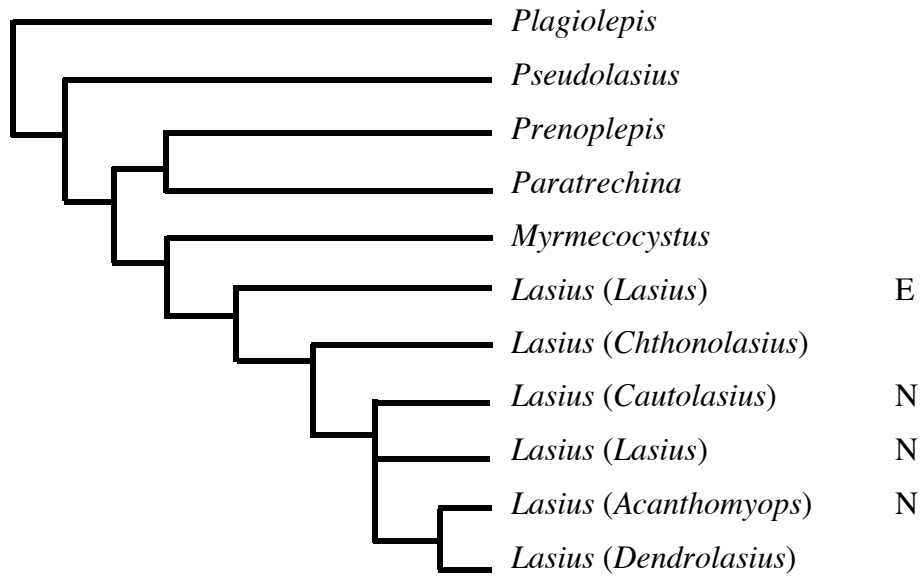

FIGURE 5.

Janda et al.'s (2004) hypothesis on the subgenera-level relationships in *Lasius* ants based on morphology.

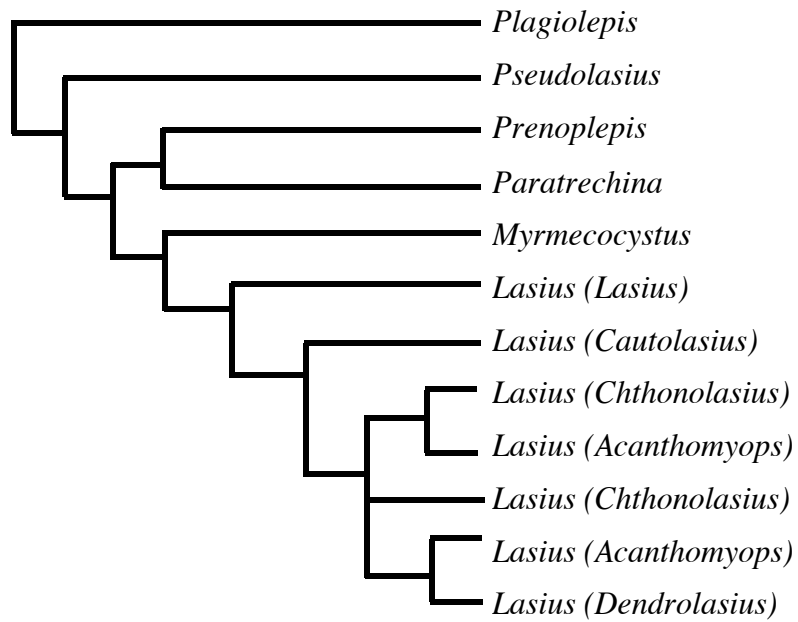

FIGURE 6.

Distribution of *Lasius* species based on Wilson (1955) and Creighton (1950). Black circles represent collection sites of *Lasius* during the summers of 2005 and 2006 included in this study (see Table 1 for detailed sight collections). * Little is known about the distribution of *Lasius californicus*.



Lasius alienus



Lasius arizonicus



Lasius californicus

FIGURE 6. Continued.



Lasius claviger



Lasius crypticus



Lasius flavus

FIGURE 6. Continued.



Lasius nearcticus



Lasius neoniger



Lasius niger

FIGURE 6. Continued.



Lasius pallitarsis



Lasius sitiens



Lasius umbratus

FIGURE 7.

Uncorrected pairwise ANG distances partitioned by codon position (83 codons analyzed). Each point represents one pair of taxa appearing in the phylogeny. The Y-axis presents the overall difference for the genetic sequences for that pair. The X-axis represents genetic distance partitioned by the three codon positions.

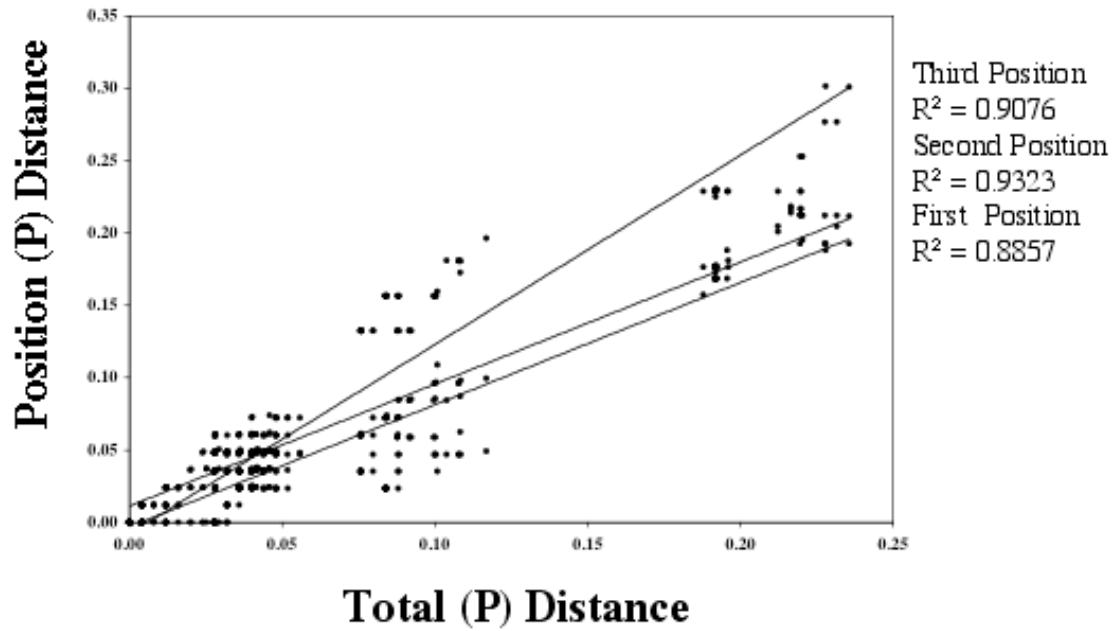

FIGURE 8.

Uncorrected pairwise COI distances partitioned by codon position (261 codons analyzed). Each point represents one pair of taxa appearing in the phylogeny. The Y-axis presents the overall difference for the genetic sequences for that pair. The X-axis represents genetic distance partitioned by the three codon positions. All three positions display linearly increasing substitutions that negate evidence of saturation of nucleotide changes in codon position as would be exhibited by an asymptoting curve.

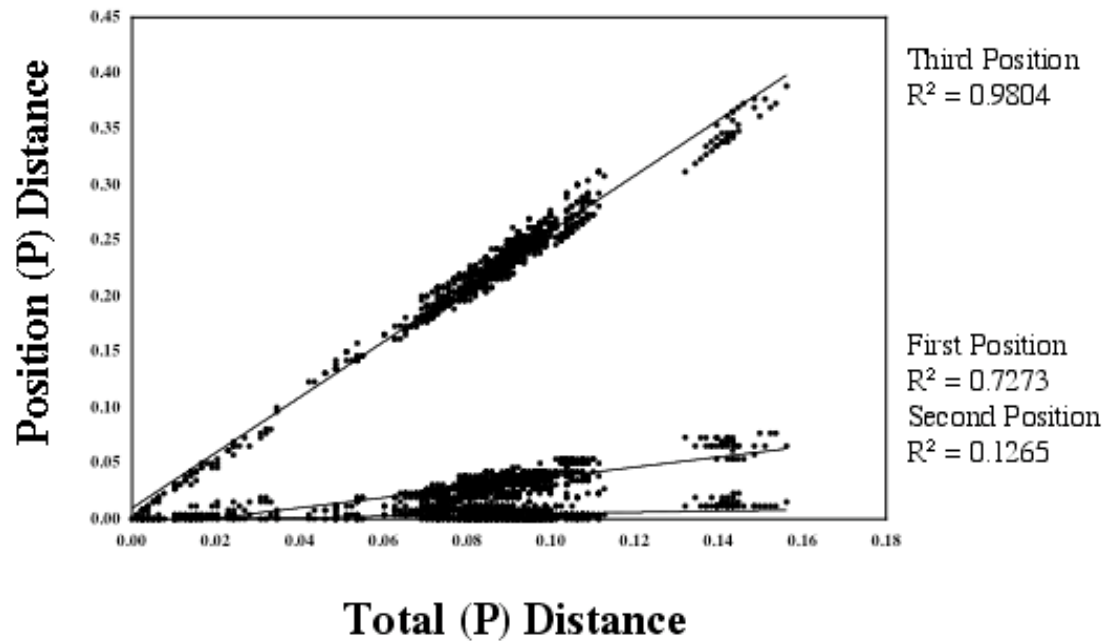

FIGURE 9.

Single COI gene tree recovered under maximum parsimony analysis.

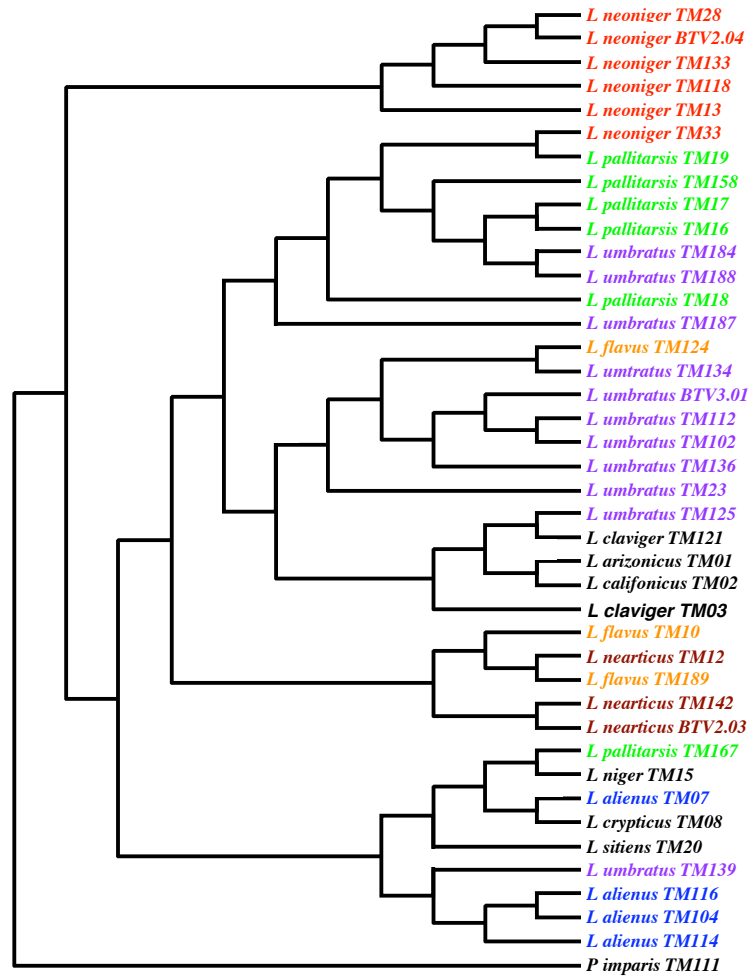

FIGURE 10.

Most likely COI gene tree recovered under ML. State locations are indicated next to each taxon (see FIGURE 6 for specific locations). * Indicate samples that were collected on the outer limits of the species range. Vertical colored bars indicate subgenera (See key).

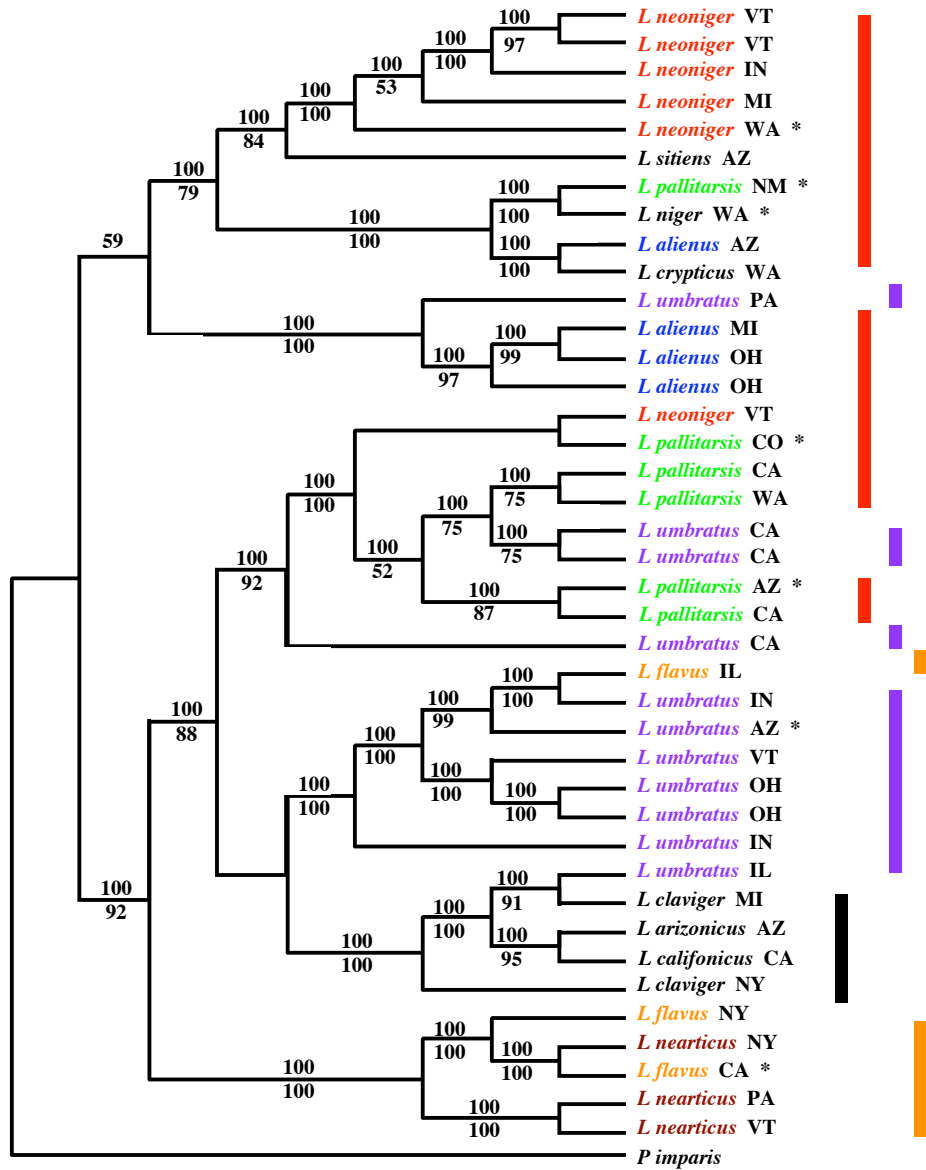



FIGURE 10. Continued. Key to subgenera.

 *Lasius*

 *Chthonolasius*

 *Cautolasius*

 *Acanthomyops*

FIGURE 12.

Bayesian consensus tree based on ANG for 28 taxa. Posterior probabilities are shown above the branches.

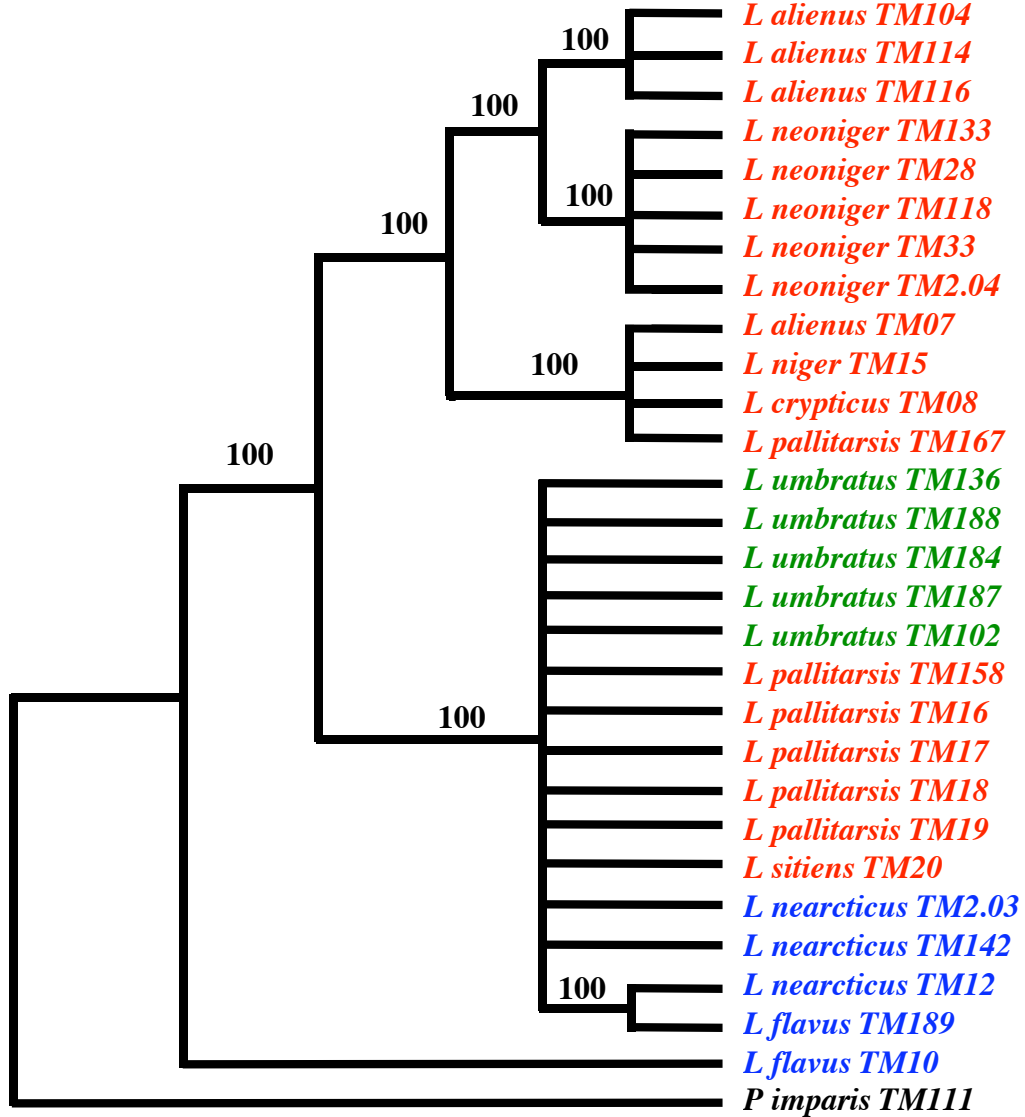

FIGURE 13.

Bayesian consensus tree based on combined data (ANG + COI) for 28 taxa. Posterior probabilities are shown above the branches.

